

■ SCOPE OF WORK

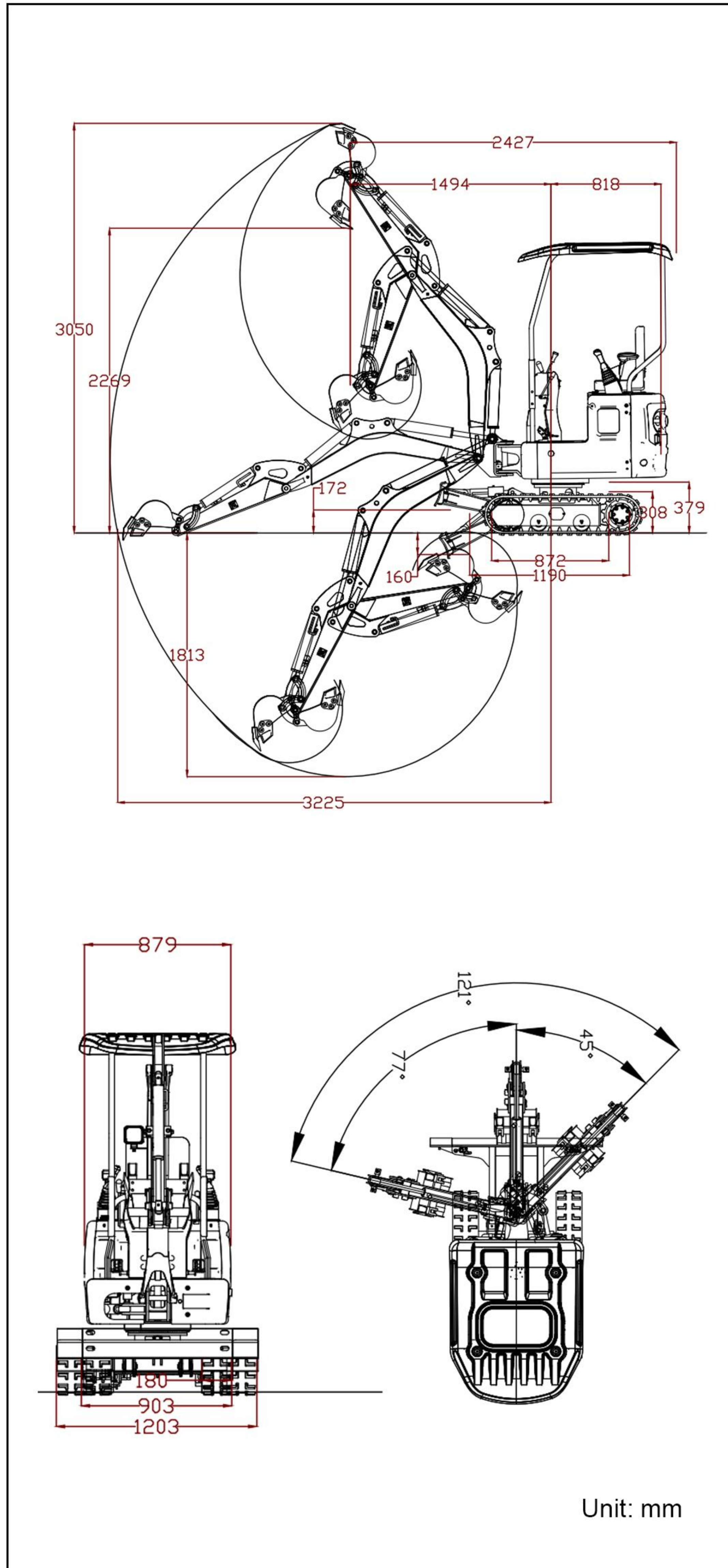

Unit: mm

■ SPECIFICATION

	Model	Unit	R319
Basic parameters	Machine working weight	lb(kg)	2307(1048.5)
	Bucket capacity	ft³(m³)	0.49(0.014)
	Travel speed low/high speed	mph(Km/h)	0-0.93(0-1.5)
	Gradeability	(%)	30
	Ground pressure	(Kpa)	25.53
	Maximum digging force	(kN)	9.2
	Maximum digging radius	in(mm)	127(3225)
	Maximum digging depth	in(mm)	71.4(1813)
	Maximum digging height	in(mm)	120.1(3050)
	Maximum unloading height	in(mm)	89.3(2269)
Maximum deflection angle	°	121	
Track extension range	in(mm)	35.4-47.2(900-1200)	
Engine	Engine brand		Kubota
	Engine model		D722
	Maximum horsepower	ps	13.9
	Maximum power	kw	10.2
	Maximum speed	rpm	2500
	Displacement	gal(L)	0.19(0.719)
	Number of cylinders		3
	Cooling method		Water-cooled
	Engine oil change amount	gal(L)	0.92(3.5)
	Fuel form		DIESEL
Fuel grade		0/-10	
Theoretical fuel consumption	gal/h(L/h)	0.3-0.4(1.1-1.5)	
Body	Transport length	in(mm)	95.6(2427)
	Transport width	in(mm)	35.6(903)
	Transport height	in(mm)	87.3(2217)
	Counterweight ground clearance	in(mm)	14.9(379)
	Bucket width	in(mm)	11.8(300)
	Boom length	in(mm)	58.1(1477)
	Arm length	in(mm)	31.5(800)
Bulldozer blade width	in(mm)	34.8(885)	

■ HYDRAULIC SYSTEM

Main pump type/model	With pilot double gear pump	Maximum set pressure (Mpa)	18MPa
Main pump brand	Tianjin walking	Travel hydraulic motor type	WDM-300
Main pump maximum flow (L/min)	13	Travel motor brand	Paiyi
Multi-way valve	THD12 multi-way valve	Motor displacement	300
Multi-way valve brand	Taifeng	Slewing hydraulic motor type	BM2-315
Rated set pressure (Mpa)	17MPa	Displacement	315

- Please read the instruction manual carefully and use the machine correctly.
- Always wear a seat belt when working. (ROPS specifications only)
- If you are operating construction machinery with a machine mass of less than 3 tons, you must take the "Special Training for Vehicle-Mounted Construction Machinery Operation" course beforehand. If the machine mass is 3 tons or more, you must take the "Vehicle-Mounted Construction Machinery Operation Skills Course".
- To prevent breakdowns and accidents, be sure to inspect the machinery regularly.
- Specific voluntary inspections are required to be carried out by an inspection company registered with the Minister of Health, Labor and Welfare or the Director-General of the Labor Standards Inspection Bureau.



MINI EXCAVATOR R319



**EXCELLENT PERFORMANCE, FULLY MEET THE
NEEDS OF VARIOUS USERS.**





EXCELLENT PERFORMANCE

[WATER-COOLED KUBOTA D722 ENGINE]

While achieving energy conservation and environmental protection
Ensure high power output of the engine.
Comply with EPA4 and Euro 5 emission standards.
Low noise, low emissions, no impact on people and the environment.



DIESEL ENGINE

10.2kw/2500RPM

[THROTTLE REGULATOR]

when working, the accelerator can be adjusted according to TOT and intensity of the work, making the work more humanized.



[BULLDOZER]

The bulldozing shovel increases the rib plate, the strength is stronger, the service life is increased, and there is butter at the connection Empty, more convenient to lubricate



RELIABLE JOB PERFORMANCE

[Rear super small turn]

Minimize the part of the turning beyond the outside of the track as much as possible, so the machine can turn safely and securely. Ease of operation is ensured even in narrow working environments.

Maximum digging radius **3225mm**

Maximum digging depth **1813mm**

Maximum digging height **3050mm**

Maximum dumping height **2269mm**

Transport width (A): **903MM**

Transport height (B): **2217MM**

Transport length (C): **2427MM**



[LED lights]

Make night work safer



[Reinforced Chassis]

Equipped with engineered rubber tracks featuring a herringbone pattern, these tracks provide excellent shock absorption during operation, effectively reducing fatigue for operators. Constructed with an inner structure of three layers of steel wire and steel plates, the outer layer is wrapped in durable natural engineered rubber for enhanced strength and longevity.



[Built-in travel motor]

It is not easy to be exposed, which can effectively avoid damage caused by collision, debris, stones, etc. during construction, greatly improving the service life and safety of the equipment.



[Rear view is wide]

There is no obstruction or blind spot at the rear, which prevents accidents during the rotation process and ensures the personal safety of surrounding workers.

[Centralized design of operation buttons]

Integrating multiple control functions into the travel control area makes the cab layout more compact, beautiful and neat, while also leaving more space for other instruments or control devices. The centralized layout eliminates the need for operators to frequently turn around or look down different locations, making the operating posture more natural, effectively reducing misoperation and physical fatigue, and improving driving comfort.



[Metal Guard]

The machine cover is made of steel plate, which is not easy to be damaged. Even if damaged, it is easy to repair.

[Oil-filled tensioning]

Oil-filled tensioning, the tensioning spring contracts, the track can fit the protrusions well, protecting the track

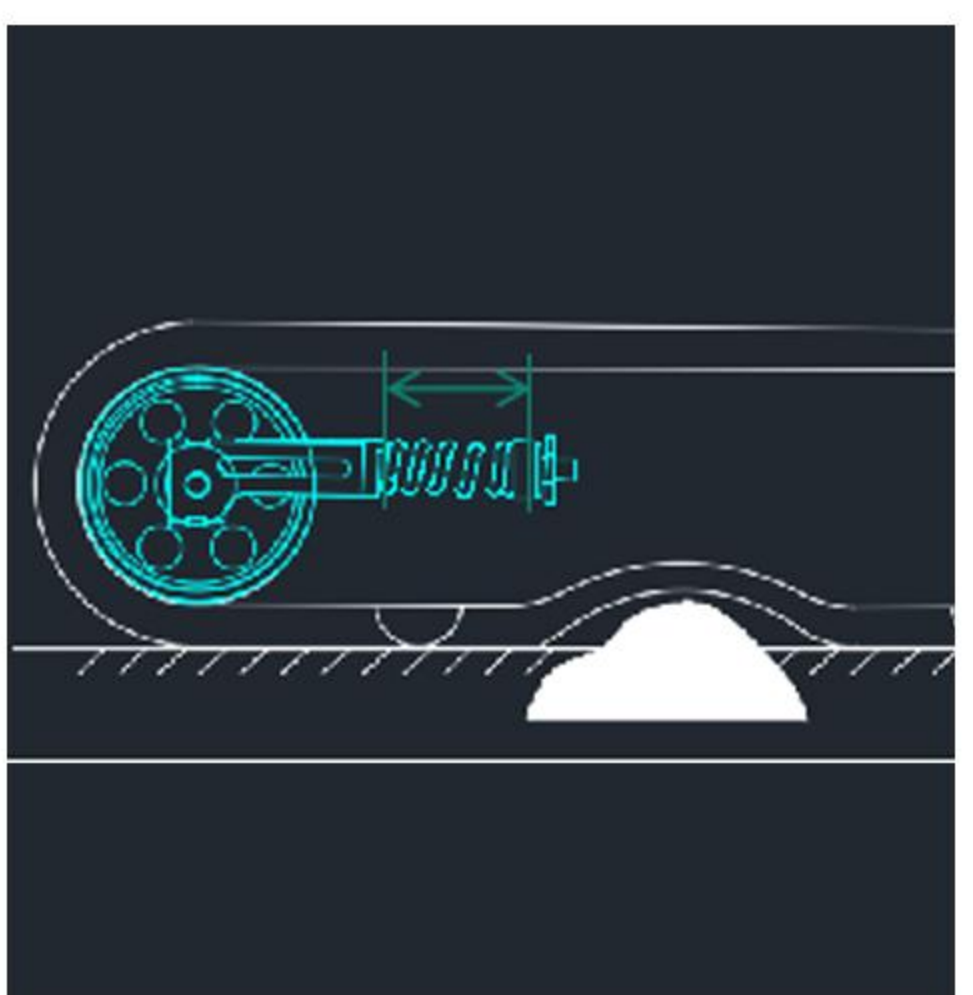



OPERATION AND MAINTENANCE

[Rear boom cylinder]

You can scoop up large stones and concrete pieces with the bucket, load them onto a dump truck, or work with a mounted breaker without worrying about damaging the boom cylinder.

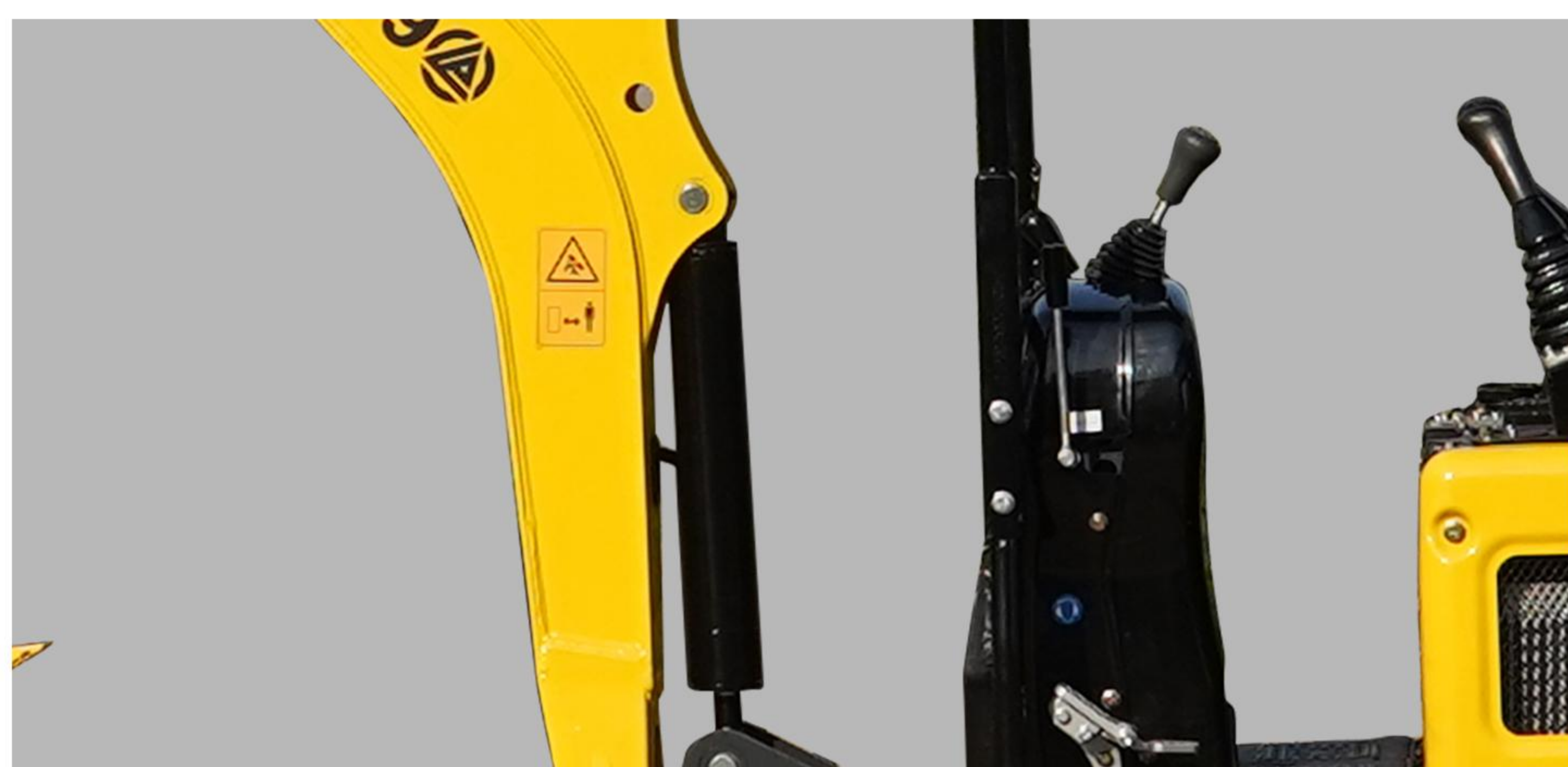

[Built-in tubing]

The oil pipe is placed inside the boom to effectively prevent external scratches, bumps, sun and rain, and extend its service life.

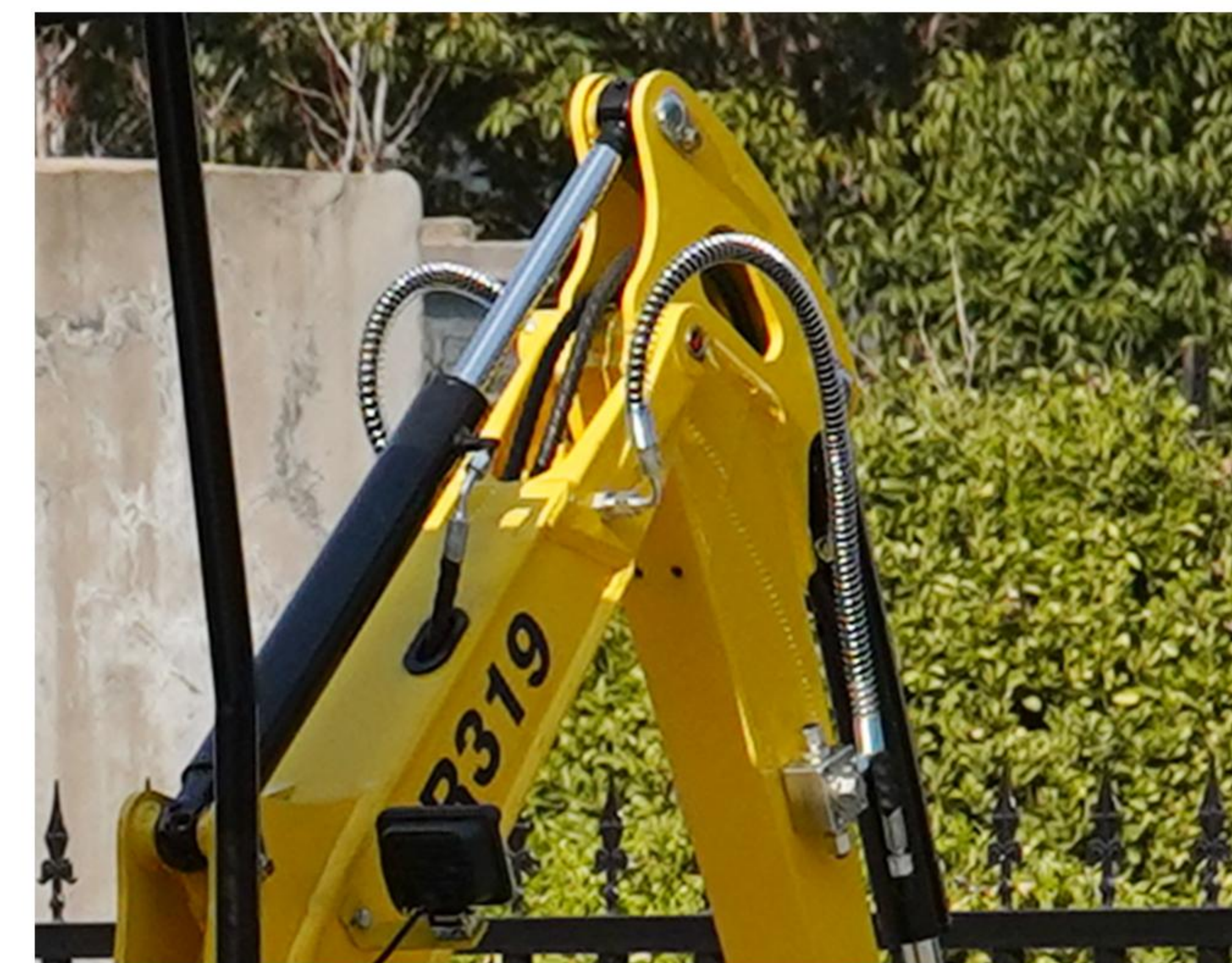

[Adjustable Suspension]

The best operating position can be set according to the driver's body shape and preference, making driving more comfortable.

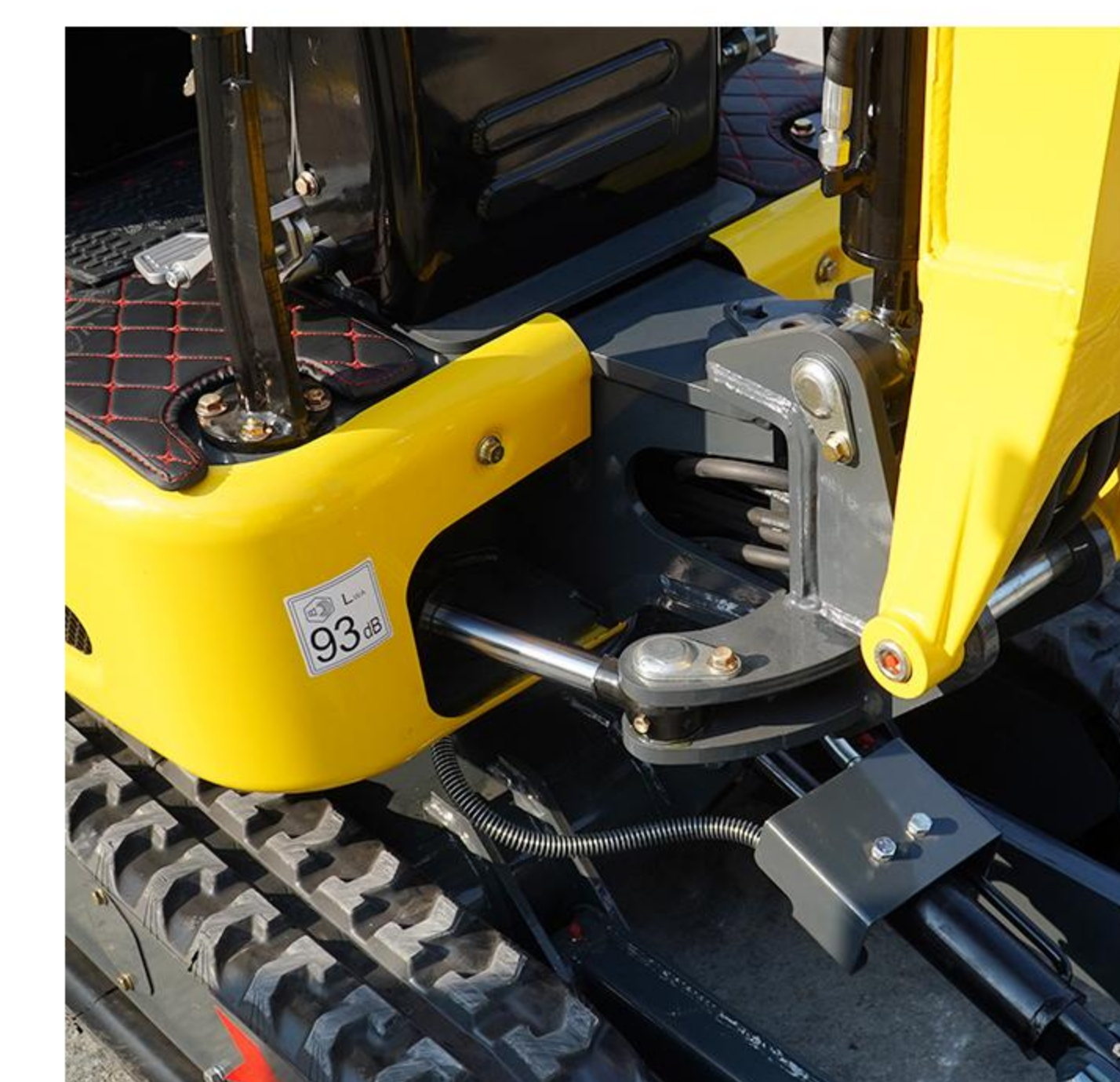

[Upper arm side swing]

Multi-angle operation can be achieved without moving the whole machine, which is particularly suitable for narrow or complex working conditions



[Retractable crawler tracks]

The telescopic function can be flexibly adjusted according to on-site needs, enhancing the versatility and adaptability of the machine.

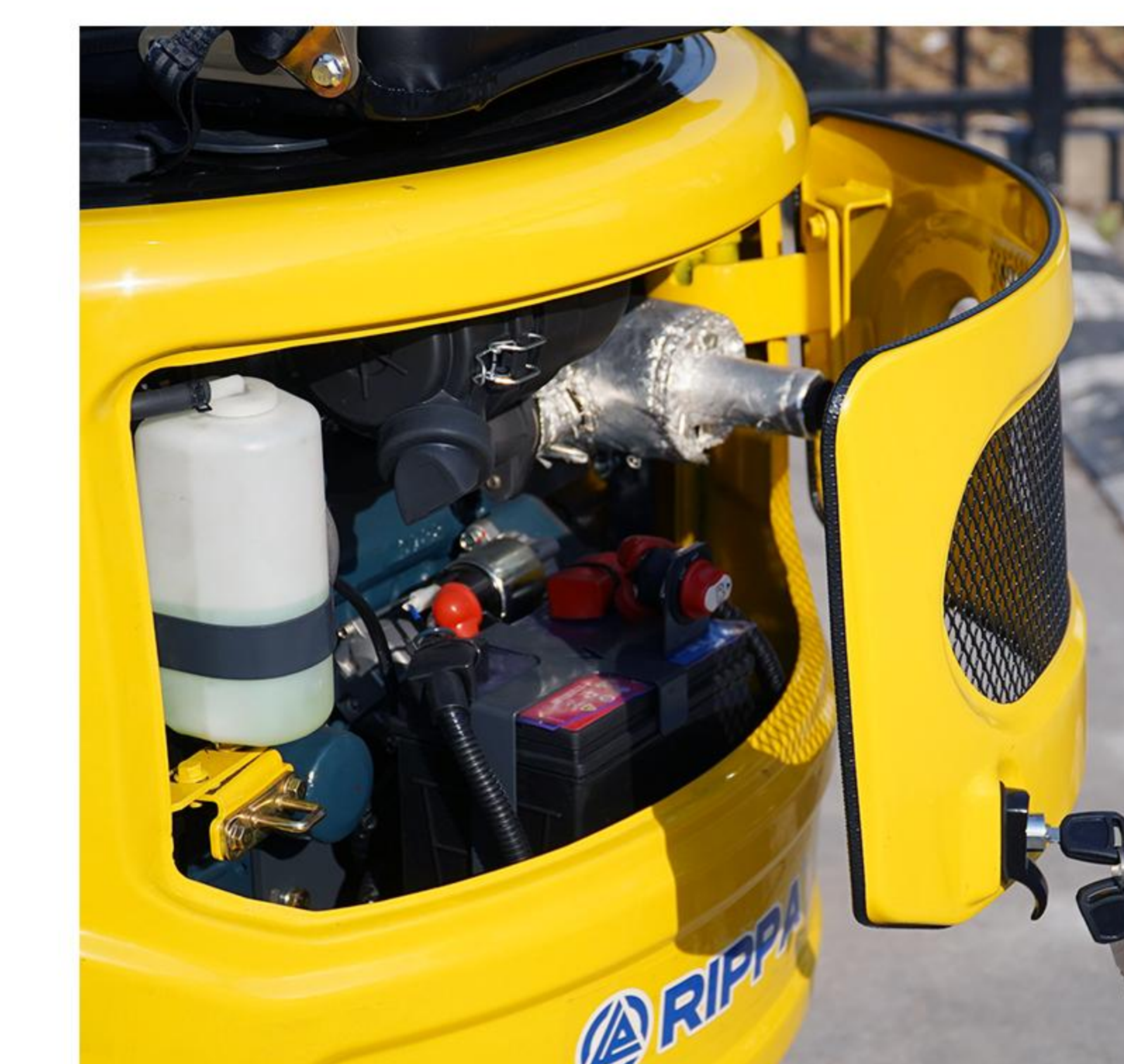

[Rear door design]

The tail guard can be opened to facilitate inspection and maintenance, greatly improving work efficiency

WE ARE RIPPA

Shandong Rippa Machinery Group Co., Ltd. is located in the sixth industrial park of Jining High-tech Zone, Shandong Province. It is a state-owned high-tech enterprise with import and export rights.

The company's employees are energetic and enterprising, constantly creating the legend and fame of the rippa!



Shandong Rippa Machinery Group Co., Ltd.

Address: Rippa Group Co., Ltd., Guang'an Road, High-tech Zone, Jining City, Shandong Province

Some specifications are based on engineering measurements and may differ from actual conditions. Specifications are for comparison purposes only and are subject to change without notice. Specifications of individual RIPPA devices may vary due to normal variations in design, manufacturing, operating conditions and other factors. Some images of RIPPA devices are not limited to standard packages.



www.rippa.com